

CX14 S2 1150X525

SMALL SIZE, GREAT MANOEUVRABILITY



CX14

The CX14 electric pallet truck is suitable for carrying loads on smooth or paved surfaces. Its small size and turning radius make it the ideal tool to work with in confined spaces, such as lorries or narrow aisles.

CX14

STEERING WHEEL AND CONTROLS

- Ergonomic tiller
- Luminous indicator for battery state control.
- Butterfly valves for traction control.
- Safety pushbutton with warning buzzer.
- Forks way up/down control positioned on both sides of the handle (only on CX14).
- Hour counter in the Plus and Gel versions (only on CX14).
- "Tortoise" pushbutton for slow motion, which allows for the carrying out of operations with the tiller in vertical position.



BATTERIES

Extractable monoblock consisting of two 12V batteries connected in series, located in a dedicated compartment specially designed to allow a rapid access from the top to make easier battery inspection and substitution.

The Plus version has a very powerful battery that gives better endurance and longer lifetime.

GEL batteries available.



BATTERY CHARGER

Built-in battery charger provides a convenient charging solution and eliminates the need to remove the battery from the machine.



STABILIZERS

Two stabilizing wheels enable movement even on more difficult surfaces thus guaranteeing maximum stability in any condition of use.



COMPACT DIMENSIONS

Thanks to its compact design, the CX14 delivers excellent manoeuvrability for truly effortless handling and more efficient work.



ROLLERS

Standard configuration provided with single polyurethane rollers. Available tandem rollers as optional.

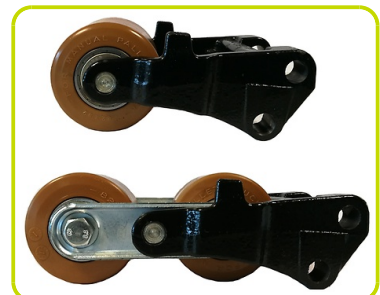

Description

1.1 Fabricante	LIFTER		
Elevación	ELECTRIC		
1.3 Grupo tracción	ELECTRIC		
1.4 Conducción	Acompañante		
1.5 Capacidad carga	Q	Kg	1400
1.6 Centro gravedad	c	mm	600
1.8 Distancia de la carga	x	mm	935
1.9 Distancia entre ejes	y	mm	1195

Weights

2.1 Peso con batería	Kg	214
2.2 Carga sobre ejes con carga, atras	Kg	1047
2.2 Carga sobre ejes con carga, delante	Kg	567
2.3 Carga sobre ejes sin carga, delante	Kg	179
2.3 Carga sobre ejes sin carga, atras	Kg	35

Tyres/Chassis

3.1 Tyres: front wheels	GOMA		
3.1 Tyres: stabilizers wheels - front	POLY.C.		
3.1 Ruedas traseras	POLY.C.		
3.2 Dimensiones ruedas delanteras - Ancha	mm	76	
3.2 Dimensiones ruedas delanteras - Diametro	mm	250	
3.3 Dimensiones ruedas traseras - Diametro	mm	82	
3.3 Dimensiones ruedas traseras - Ancha	mm	80	
3.4 Dimensiones Ruedas Laterales (Ø)	mm	100	
3.4 Dimensiones Ruedas Laterales (ancho)	mm	40	
3.5 Dimensiones ruedas traseras - Q.ty (X=motriz)	nr	2	
3.6 Vía delantera	b10 mm	506	
3.7 Vía trasera	b11 mm	375	

Dimensions

4.4 Elevación	h3 mm	115
4.9 Altura del timón max	h14 mm	1242
4.15 Altura horquillas bajadas	h13 mm	85
4.19 Longitud total	l1 mm	1650
4.20 Longitud de timón a horquillas	l2 mm	500
4.21 Ancho total	b1 mm	720
4.22 Dimensiones horquillas	s mm	50
4.22 Dimensiones horquillas	e mm	150
4.22 Dimensiones horquillas	l mm	1150
4.25 Ancho horquillas	b5 mm	525
4.32 Altura libre inferior, con carga, al centro entre ejes	m2 mm	35
4.34 Pasillo de trabajo para palet 800x1200 longit.	Ast mm	1900
4.35 Radio de giro	Wa mm	1435

Performances

5.1 Travel speed laden	Km/h	4.5
5.1 Travel speed unladen	Km/h	4.7
5.2 Velocidad de elevación con carga	m/s	0.02
5.2 Velocidad de elevación sin carga	m/s	0.03
5.3 Lowering speed laden	m/s	0.04
5.3 Lowering speed unladen	m/s	0.04
5.8 Max gradeability laden	%	5
5.8 Max gradeability unladen	%	10
5.10 Freno De Servicio		Eléctrico

Electric motors

6.1 Drive motor power	kW	0.7
6.2 Lift motor power	kW	0.4
Tipo de batería	Type	AUTOMOTIVE
6.4 Battery voltage	V	24
6.4 Battery capacity, Min	Ah	70
6.4 Battery capacity, Max	Ah	70
6.5 Battery weight, Min	Kg	32
6.5 Battery weight, Max	Kg	32

Integrated battery and battery charger

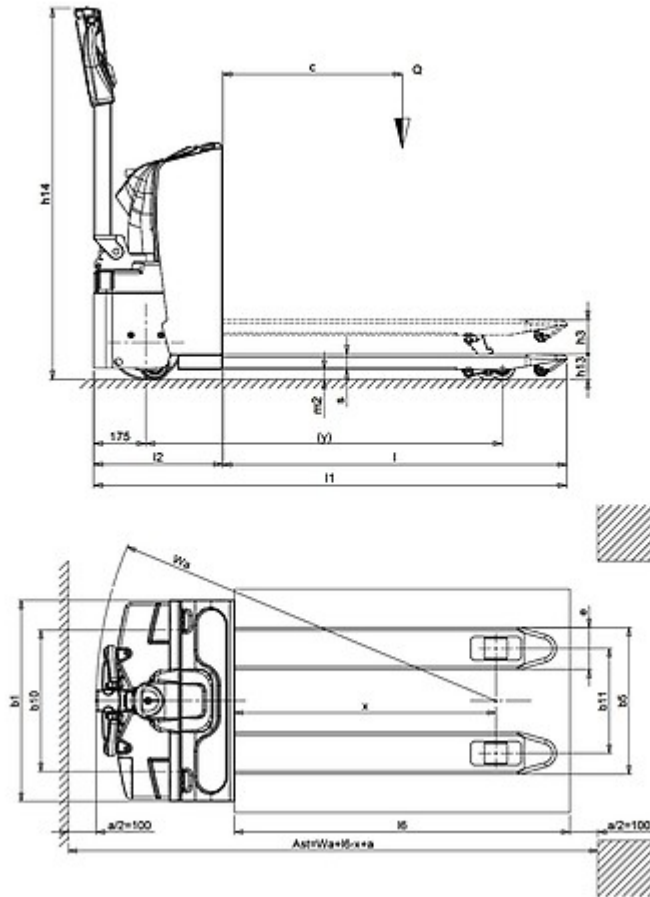

The information is aligned with the Data file at the time of download. Printed on 30/08/2018 (ID 460)

©2018 | PR INDUSTRIAL s.r.l. | All rights reserved | Image shown may not reflect actual package. Specifications subject to change without notice

